



PRESENTS:

**SWAP:  
CYCLONES AND FILTER  
POWDERS DISSOLVING SYSTEM**

TECHNICAL DATA

---



## 1.1 TECHNICAL DESCRIPTION

Euroelettra's SWAP dissolving system permits to regenerate slip starting from the powder recovered from cyclones and filter. The system manages the immediate and continuous recovery of the powder, which is transported to the dissolving machine through conveyor belts.

Regenerated slip will have the desired density thanks to the load cells installed under the machine; the cells measure constantly the mixture's weight.

The SWAP machine, completely automated, is equipped with an electrical panel that controls the pump unit using a frequency inverter (also included) and regulates the incoming of water and powders checking the weight of the whole machine.

The dosage of water and powder can be easily set up using the specific interface keypad, which is placed on the front of the panel and controls the machine's automation.

The electrical panel is provided with PLC to manage the various regulations of the pump's engine, the water and powder balance and the automation of the system itself.

**DISSOLVING MACHINE**



**KEYPAD WITH TOUCHSCREEN**



## 1.2 MACHINE CAPACITY AND OPERATIONS

The SWAP machine can recover powders from spray dryer's cyclones and filter and reuse immediately. As seen after our previous installations and after the data evaluations, the system recovers an average value between 2000 and 6000 kg for every 8 hours' shift.

The payback, on average, will be reach within 12 months.

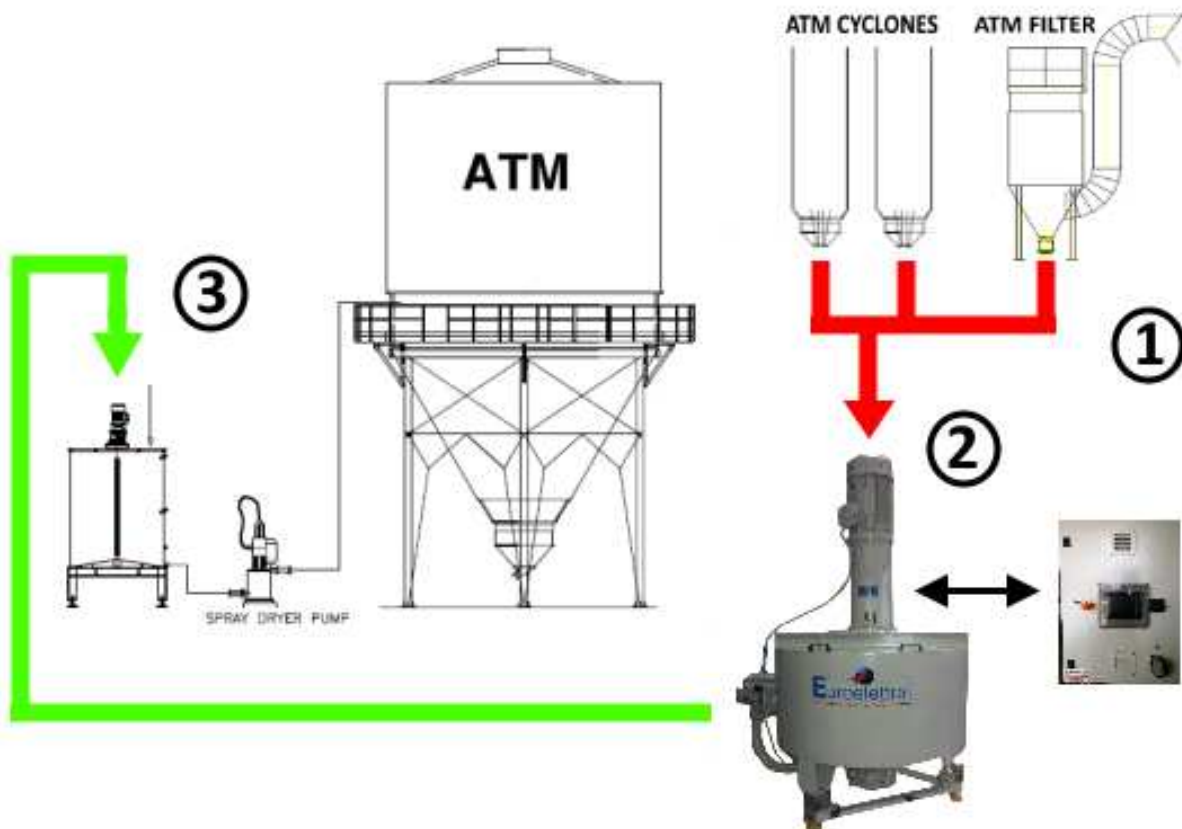

- 1) Powder is recovered from spray dryer's cyclones and filter, and then transported to the dissolving machine (this operation is normally done using conveyor belts completely automated).
- 2) Water is added to powders, and the density is set up using a touchscreen keypad: the measuring precision is guaranteed thanks to the load cells under the machine.
- 3) Regenerated slip with determined values is ready to be reintroduced in the spray dryer's circuit directly (alternatively, it can be stocked for a successive use)

Moreover, the SWAP machine can recover powders from the plant's filters, and after the dissolving process send it to storage tanks:

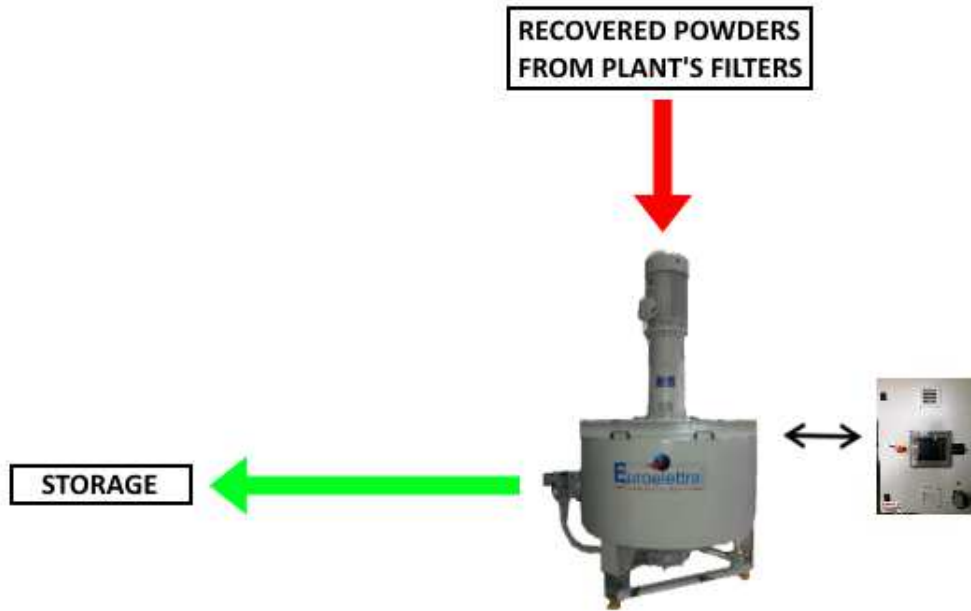

An example photo that shows the recovering process from plants' filters:



### **1.3 SYSTEM ADVANTAGES**

- HEALTH AND SAFETY. With the SWAP system, you can considerably reduce the problems connected with workers' health in the involved areas. Particularly, you can solve the problem of the powders' dispersion coming from the fall and the accumulation from the cyclones and filters: normally this powders are managed and transported by manual activities of the workers, with an inevitable substances' movement in the air.
- RECOVERY. The SWAP system leads to excellent powders' recovery performances and consequent fast payback, as seen after our previous installations and after the data evaluations. Normally, the system recovers an average value between 2000 and 6000 kg for every 8 hours' shift (for two ATM cyclones and one filter). The consequence is that you can regenerate slip in a completely automated way, that guarantees a safe and constant money saving. This can be calculated also for powders from plant's filters. On average, the payback point will be reach in 8-10 months.
- PRODUCTIVE PROCESS MAXIMIZATION. The proposed automation improve the process' flowing, removing manual tasks and inconveniences connected with the management of the recovered and collected materials: time actually spent for these activities can be used for different tasks. Furthermore, the possibility to re-insert outright powders into the spray dryer's cycle without starting from previous working phases produces savings in terms of processing times, energy and raw materials.

## 1.4 MACHINE SPECIFICATIONS

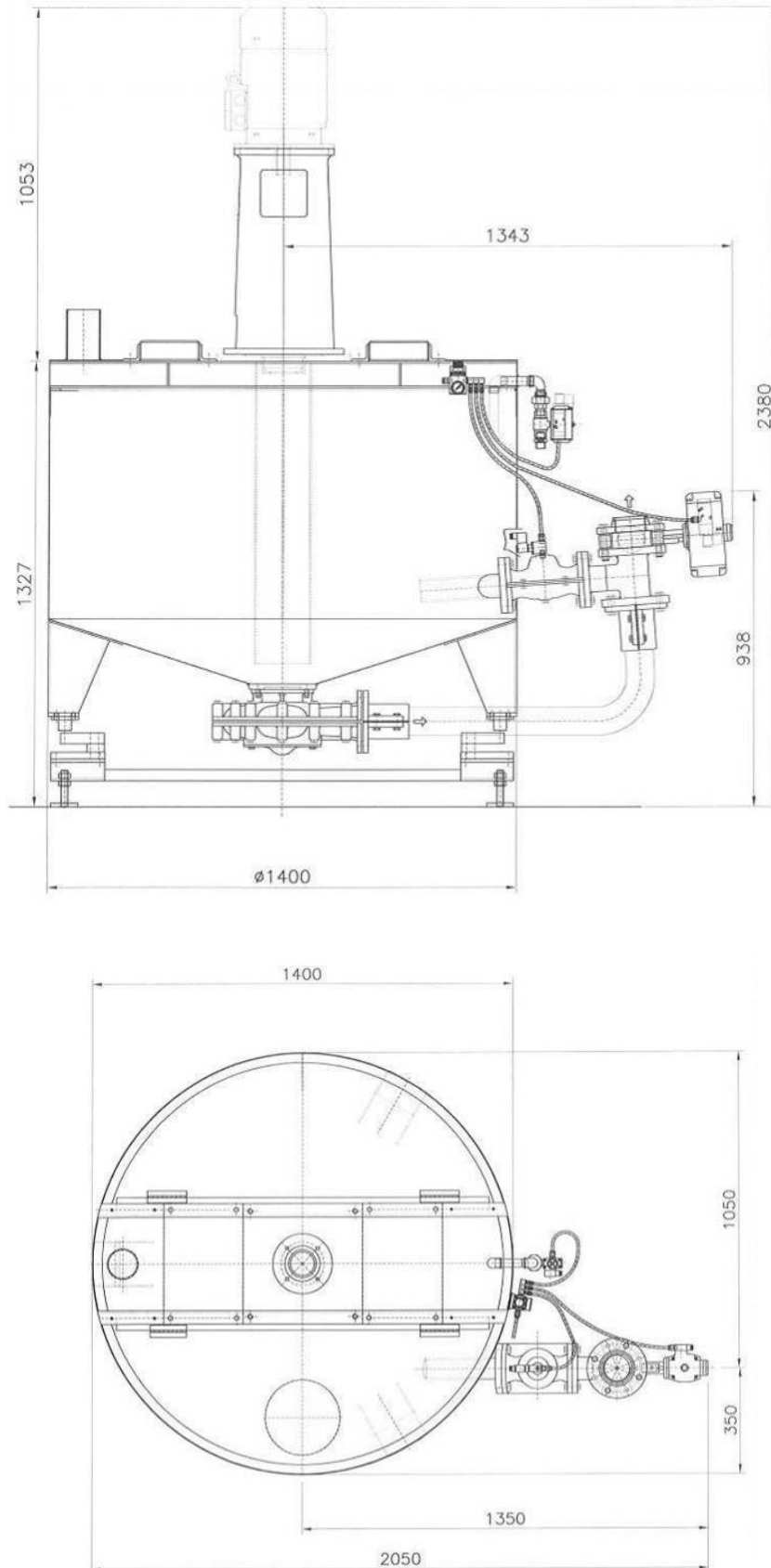

#### LOAD CELLS – TECHNICAL DATA:

Sensitivity	2 mV/V +/- 0,1%
Temperature effect on zero	0,002 % / °C
Temperature effect on span	0,002 % / °C
Compensated temperature range	- 10° / + 40°
Operating temperature range	- 20° / + 70°
Creep at nominal load in 30 minutes	0,02 %
Max supply voltage without damage	15 Volt
Input resistance	380 Ohm +/-40
Output resistance	350 Ohm +/-10
Zero balance	+/- 1 %
Insulation resistance	> 5000 MOhm
Mechanical limit in service	150 %
Destructive load	> 250 %
Deflection at nominal load	0,6 mm

#### TECHNICAL DATA:

Pump motor; 11 kW – spin/min; 1450 (4 poles) – Tank; 1300 – Capacity in litres: 1000 (approx)

#### MECHANICAL SUPPLY:

- Containment tank including rubber mixing tubes, entirely in AISI
- By-pass unit with 2 pneumatic valves:
  - No.1- Valve; new style butterfly valve NC/PA Ghibson LUG DN 80 PN 10/16 inox disk held in NBR with single-acting (spring to return) or double-acting pneumatic actuator.
  - No.1- Valve; NA/PC DN 50 using sleeve with 24 volt air pilots
  - Valve for water loading and reintegration of water to mixture - Vasfer DN ¾" F/F in inox AISI 316 with DE actuator and Namur 24 Volt solenoid valve – (all the pilot operated solenoid valves, as well as being controlled by air, are also connected together in a network). There is an arrangement for installing a weighing system with load cells.
- Ejector unit, soldered onto the tank, for mixing water/powder.
- Vertical pump with the ability to turn even when empty without damaging itself, abrasive action with rubber coated body, encircled with the super alloy Hardalloy; includes closed electrical motor with 4 poles external ventilation. – shape B3 – kW 11 –V 380/50 Hz voltage, protection class IP 55 – direct motor transmission by means of an elastic coaxial junction.

#### ELECTRICAL SUPPLY:

Joinery; Master switch 32 A; Plc omron CPU CP1L-L140T; Input expander I/O analogue CPM1-MAD11; TOUCH SCREEN 5" KEYBOARD; Man/Aut commands; Analogue weight transmitter; Omron 11 Kw; Inverter; Electrical diagrams. The electrical panel is provided separately with 10 mt. long cables (signals + weight network control) with connectors for attachment to the apparatus. The interface between the electrical panel and junction box on device will be achieved by means of multi-stranded cables 3 metres long.